



ORİMAK®

MAKİNA SANAYİ VE TİCARET LTD. ŞTİ.



ORİTEQ®

PARAMETRİK
KUTU KATALOGU

Parametric Boxes Catalogue

ORIMAK

Q-BOX



ORITEQ



200 SERİSİ / Series 200

KUTU KODU
Box Code

3D ÇİZİM
3D Drawing

2D ÇİZİM
2D Drawing

0200

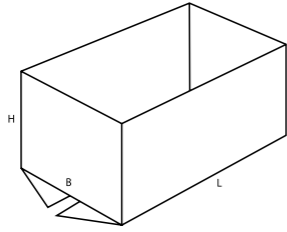

0201

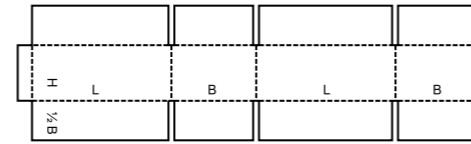
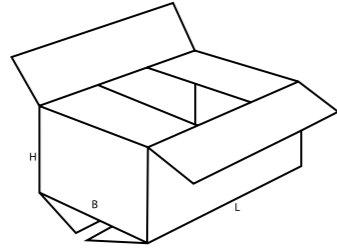

0202

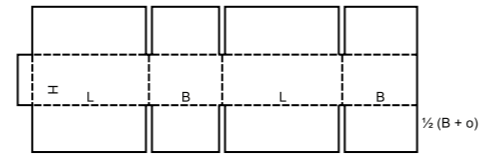
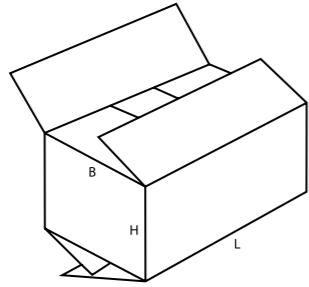

0203

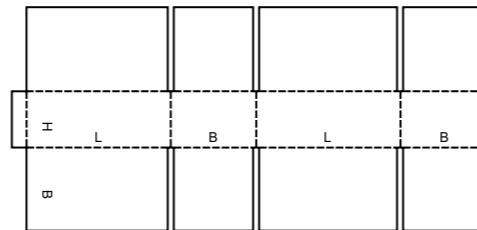
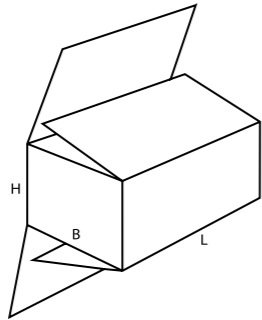

0204

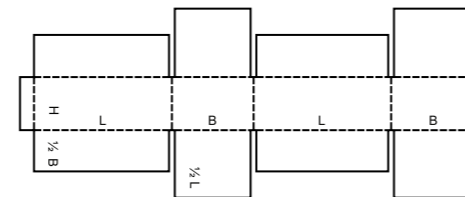
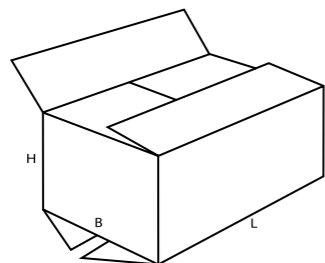

200 SERİSİ / Series 200

KUTU KODU
Box Code

3D ÇİZİM
3D Drawing

2D ÇİZİM
2D Drawing

0205

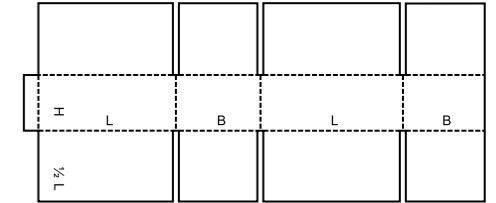
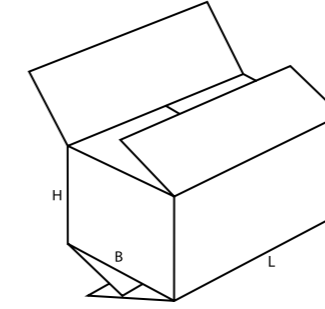

0206

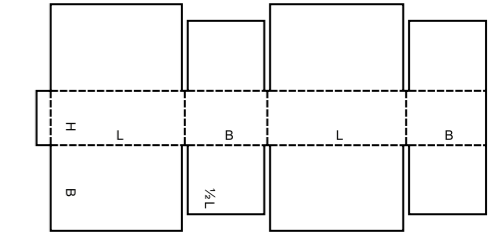
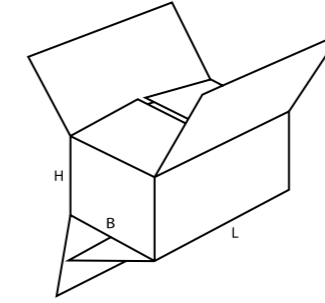

0209

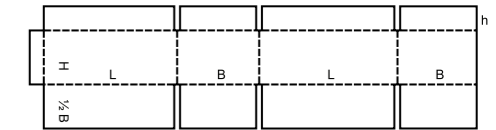
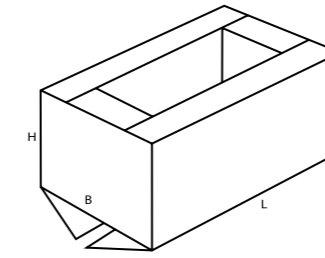

0210

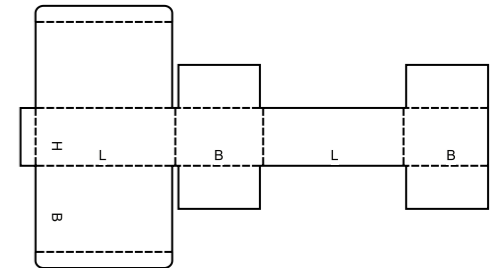
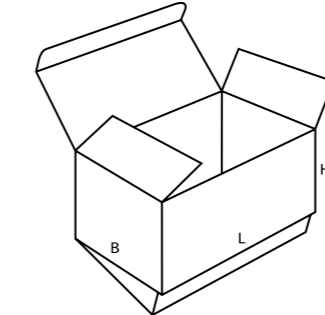

0212

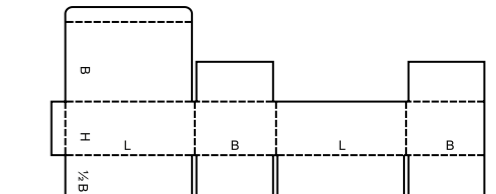
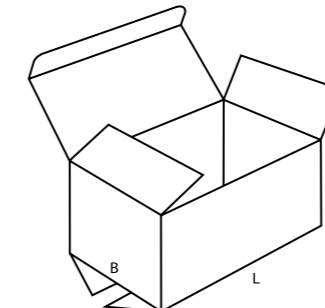

300 SERİSİ / Series 300

KUTU KODU
Box Code

3D ÇİZİM
3D Drawing

2D ÇİZİM
2D Drawing

0300

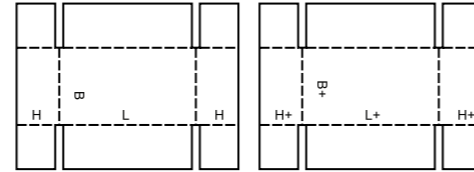
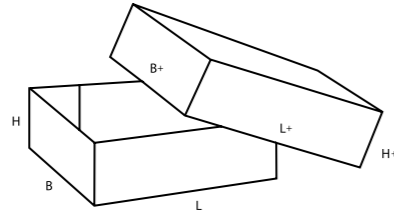

0301

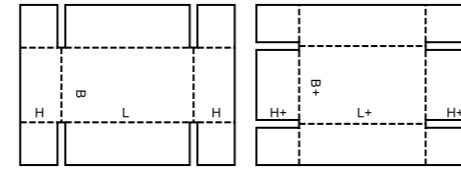
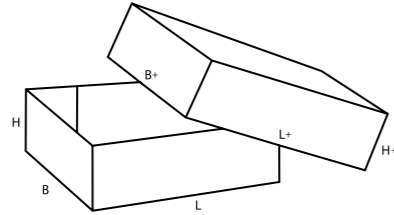

0302

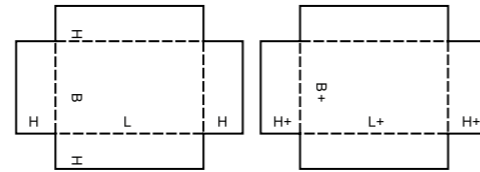
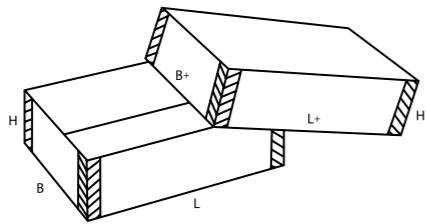

0306

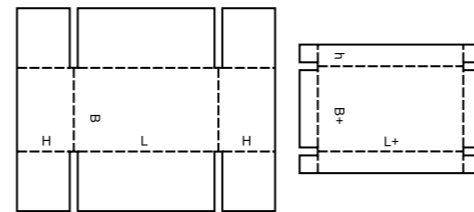
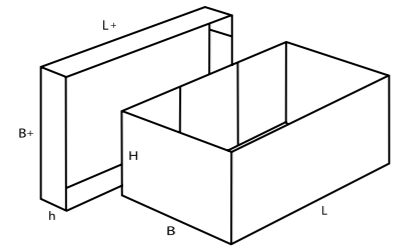

0310

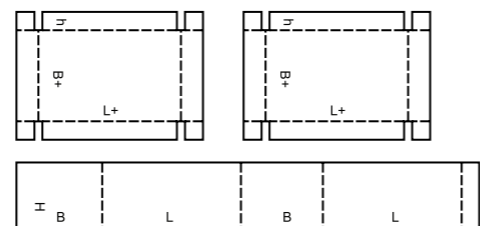
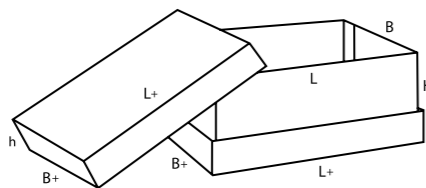

300 SERİSİ / Series 300

KUTU KODU
Box Code

3D ÇİZİM
3D Drawing

2D ÇİZİM
2D Drawing

0312

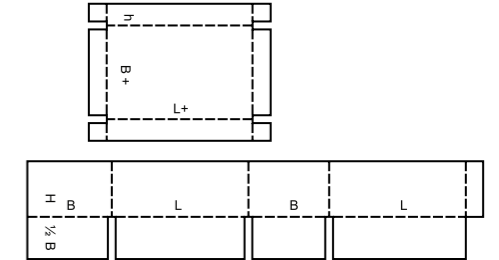
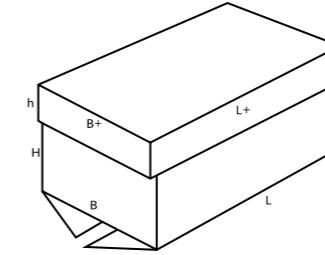

0313

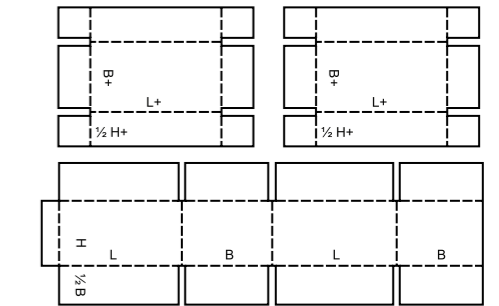
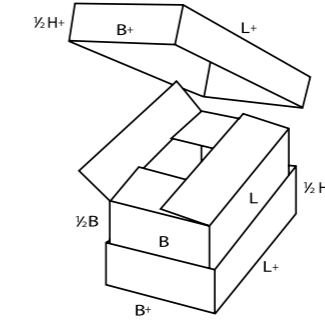

0320

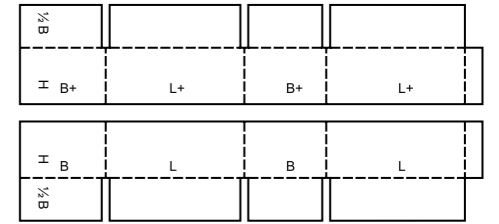
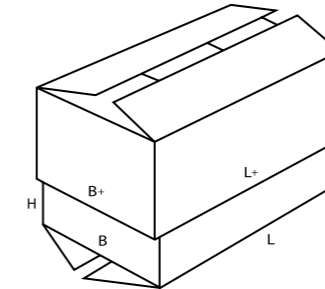

0331

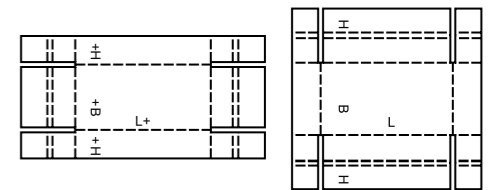
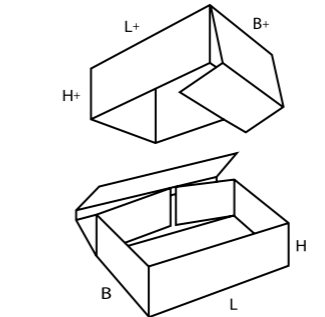

400 SERİSİ / Series 400

KUTU KODU
Box Code

3D ÇİZİM
3D Drawing

2D ÇİZİM
2D Drawing

0400

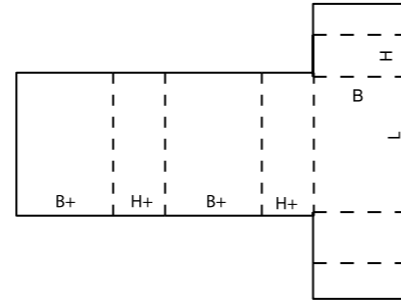
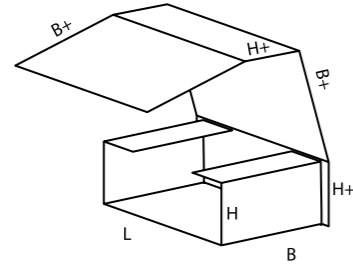

0401

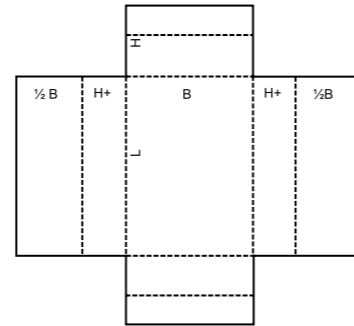
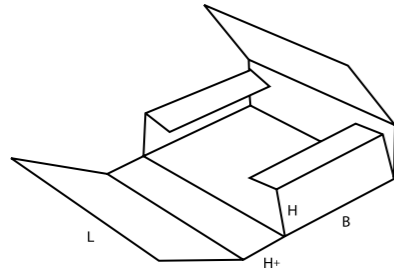

0402

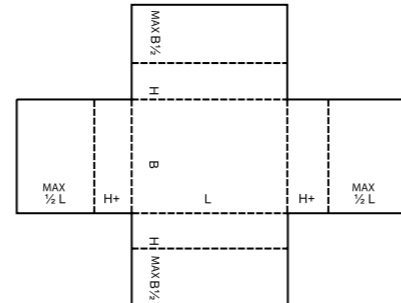
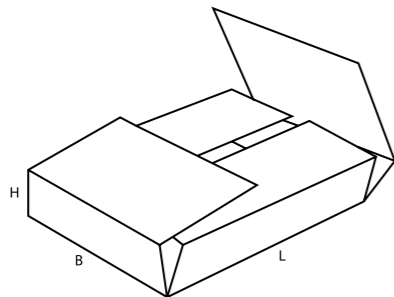

0403

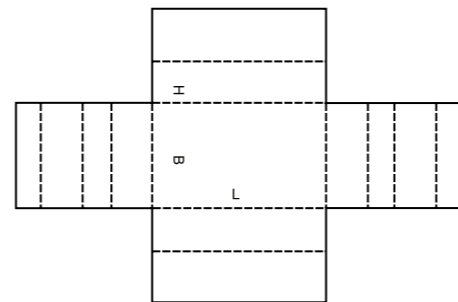
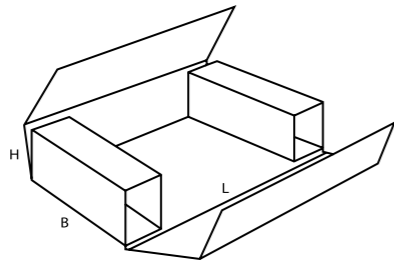

0404

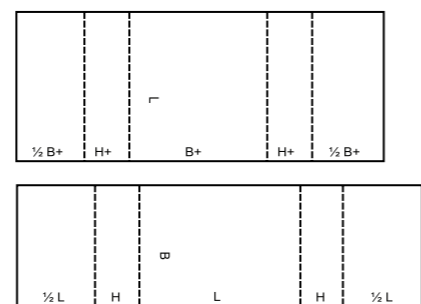
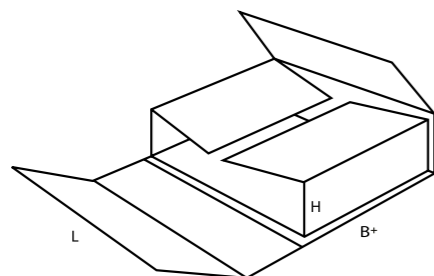

400 SERİSİ / Series 400

KUTU KODU
Box Code

3D ÇİZİM
3D Drawing

2D ÇİZİM
2D Drawing

0405

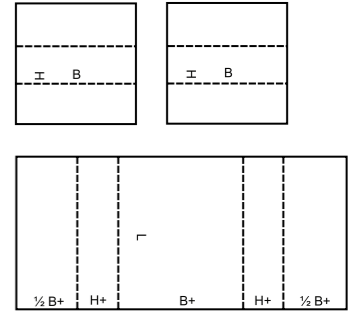
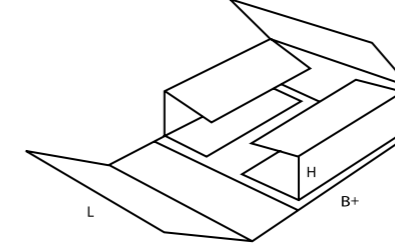

0406

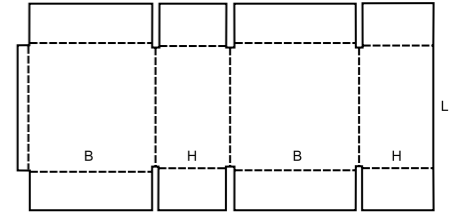
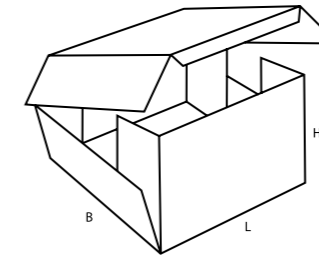

0409

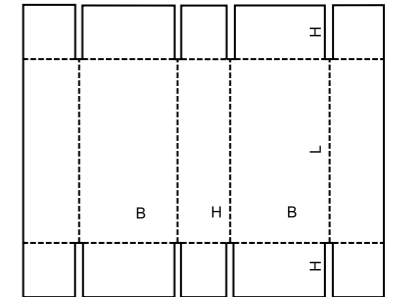
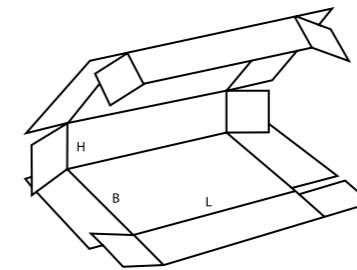

0410

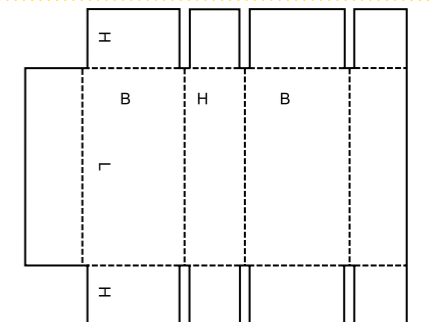
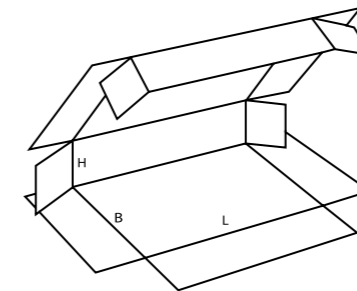

0411

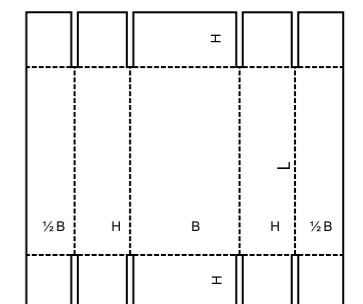
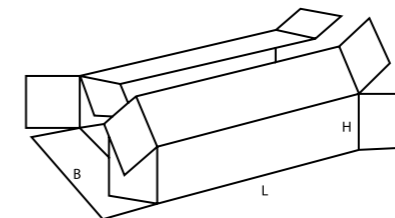

400 SERİSİ / Series 400

KUTU KODU
Box Code

3D ÇİZİM
3D Drawing

2D ÇİZİM
2D Drawing

0412

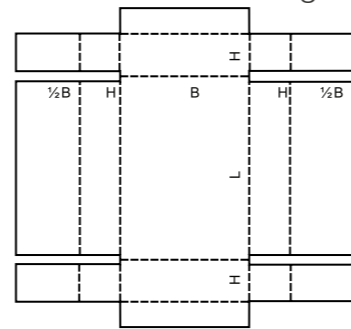
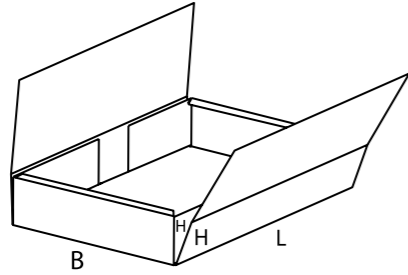

0413

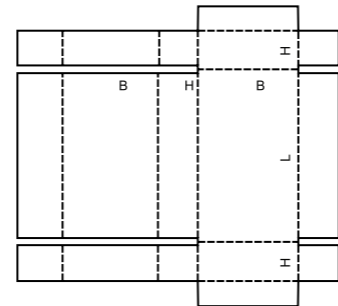
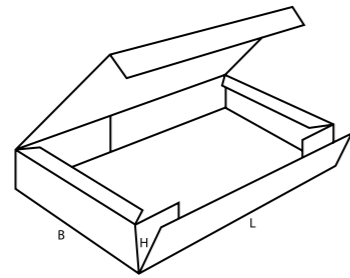

0415

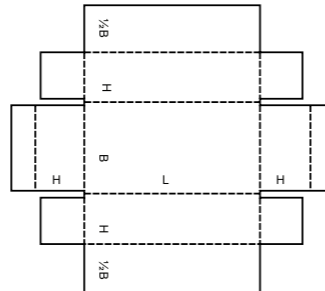
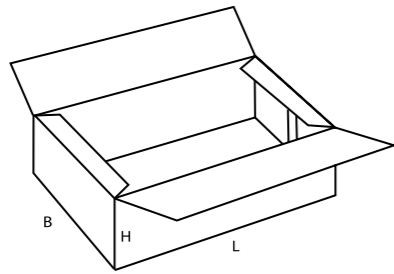

0416

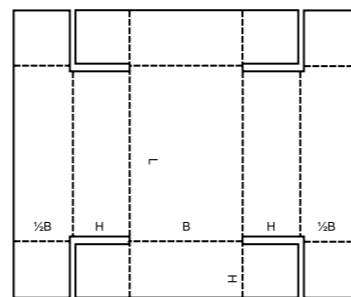
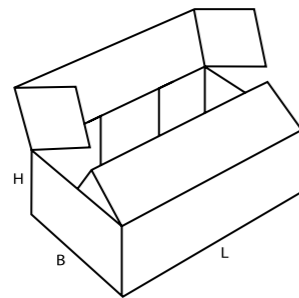

0420

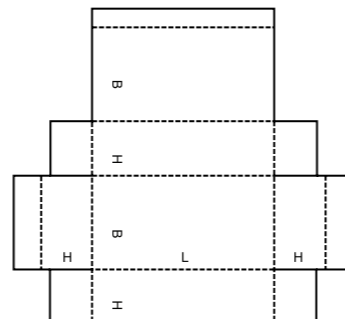
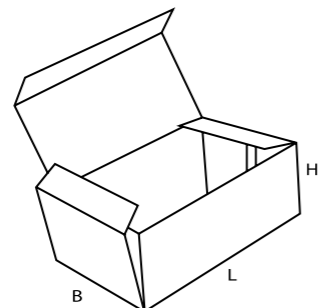

400 SERİSİ / Series 400

KUTU KODU
Box Code

3D ÇİZİM
3D Drawing

2D ÇİZİM
2D Drawing

0421

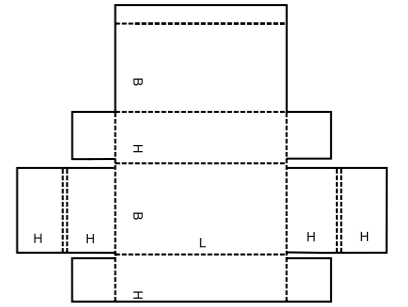
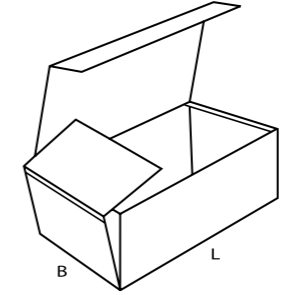

0428

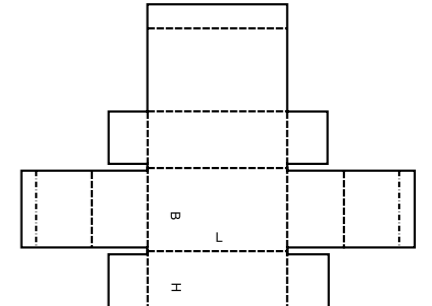
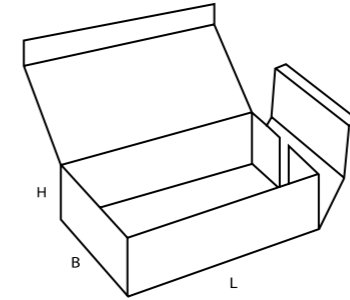

0430

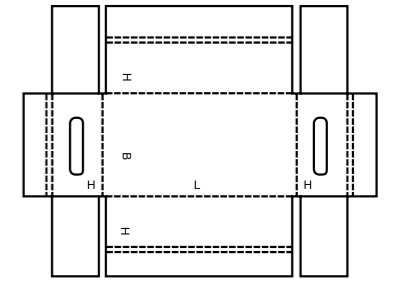
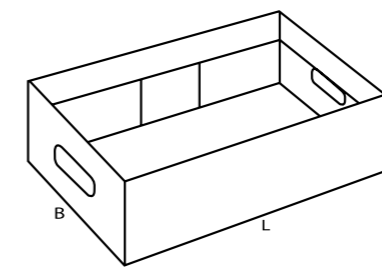

0440

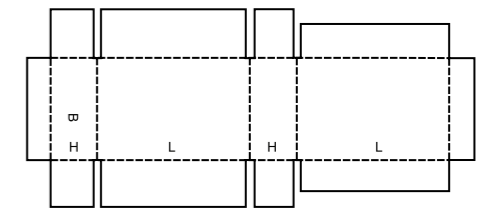
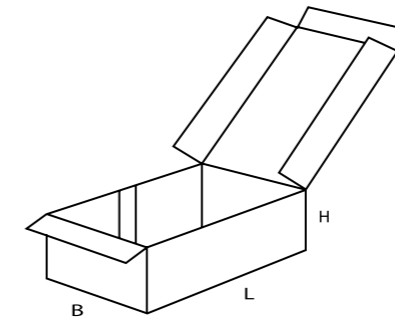

0441

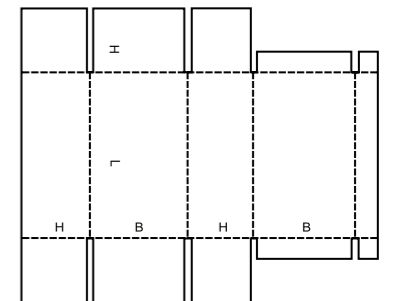
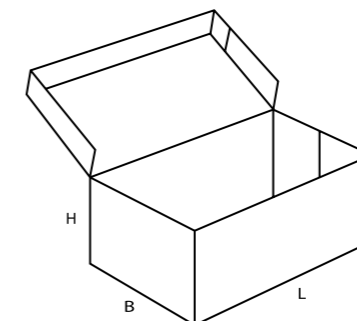

400 SERİSİ / Series 400

KUTU KODU
Box Code

3D ÇİZİM
3D Drawing

2D ÇİZİM
2D Drawing

0443

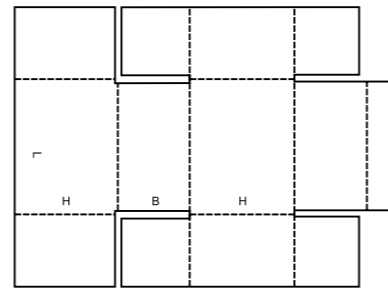
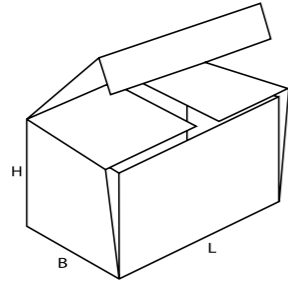

0444

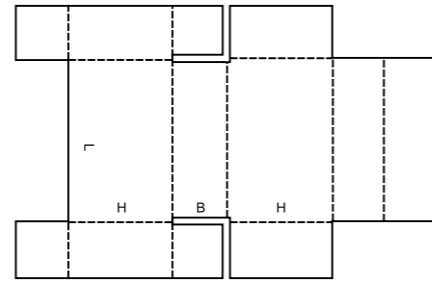
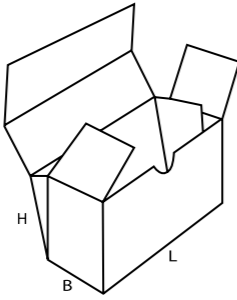

0452

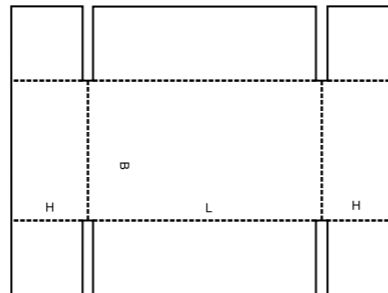
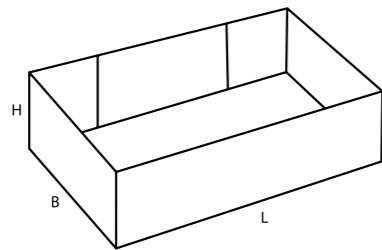

0453

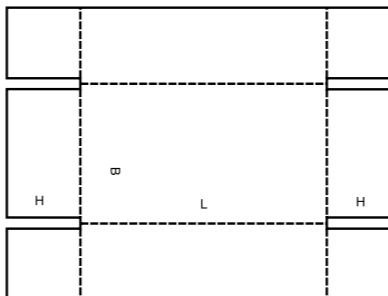
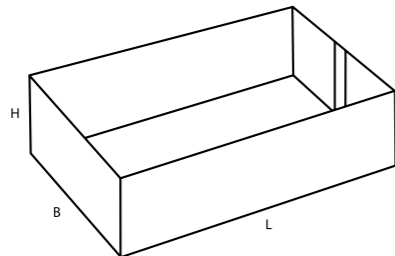

0454

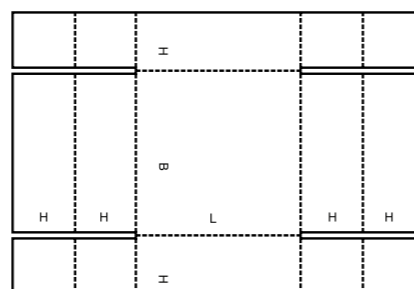
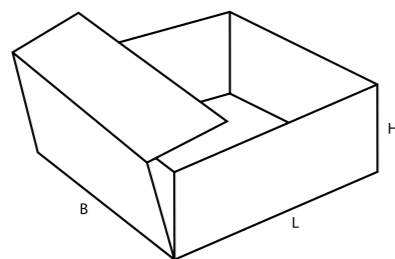

400 SERİSİ / Series 400

KUTU KODU
Box Code

3D ÇİZİM
3D Drawing

2D ÇİZİM
2D Drawing

0455

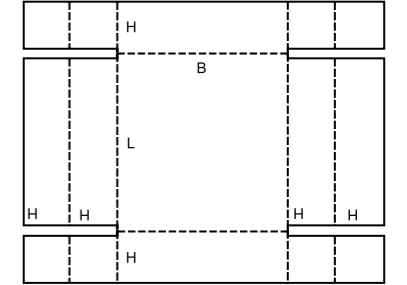
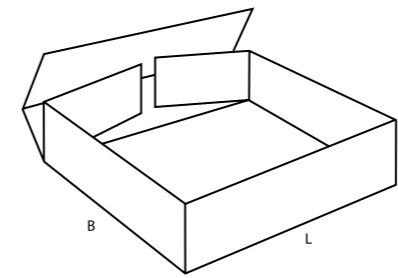

0480

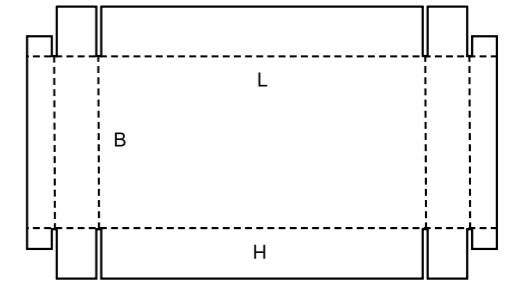
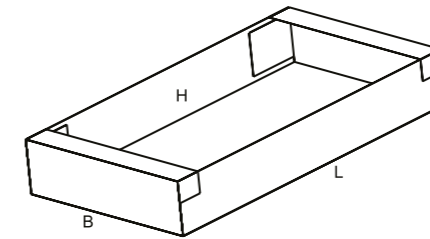

500 SERİSİ / Series 500

KUTU KODU
Box Code

3D ÇİZİM
3D Drawing

2D ÇİZİM
2D Drawing

0501

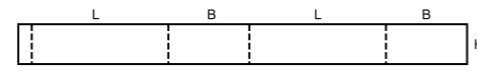
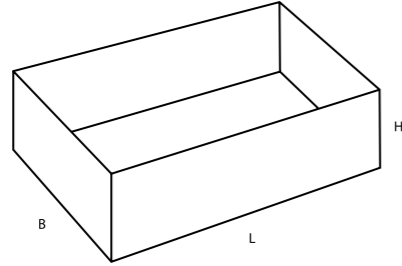

0502

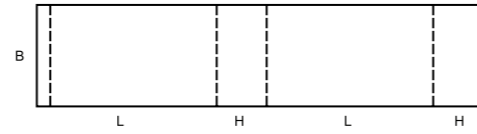
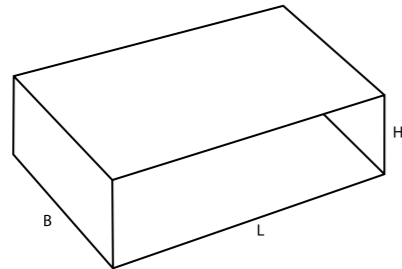

0503

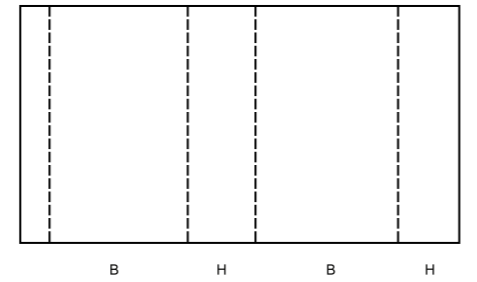
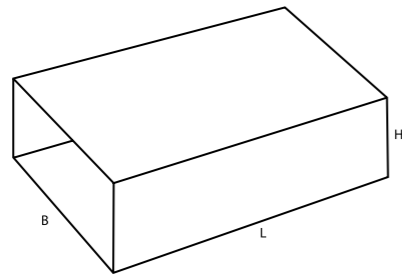

0504

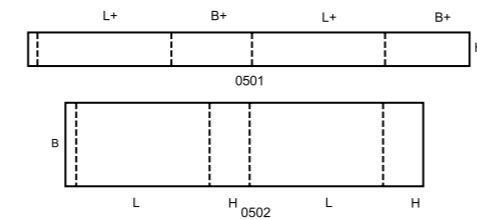
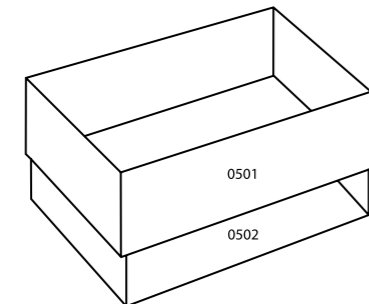

0505

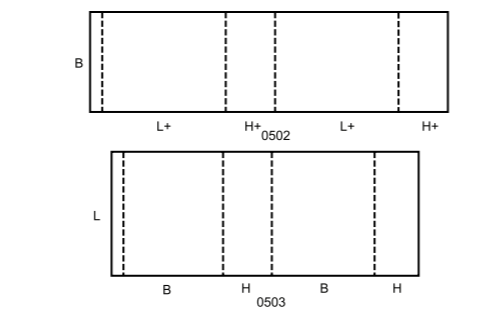
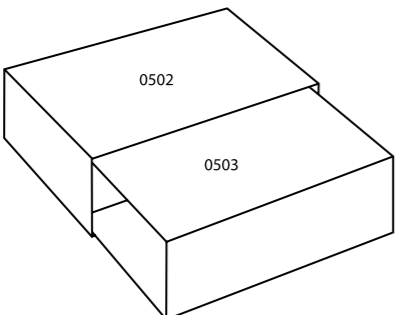

500 SERİSİ / Series 500

KUTU KODU
Box Code

3D ÇİZİM
3D Drawing

2D ÇİZİM
2D Drawing

0507

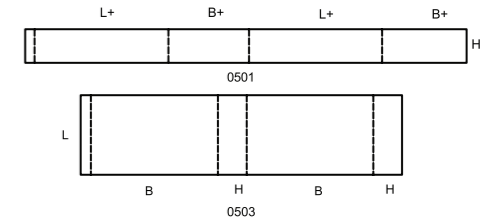
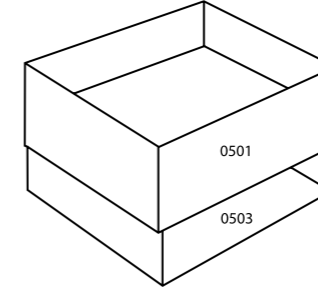

0509

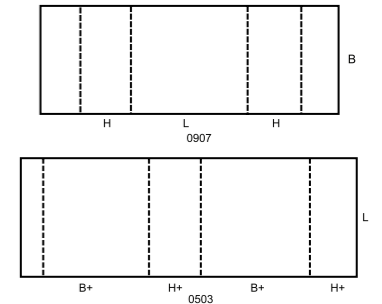
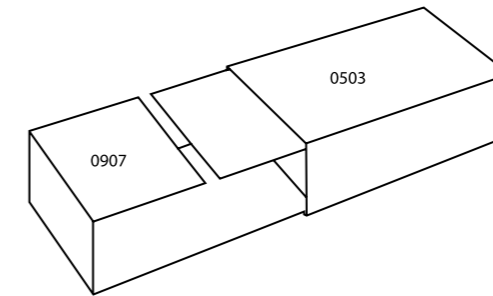

0510

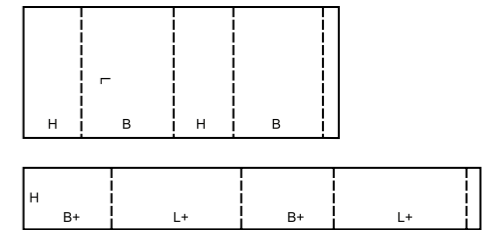
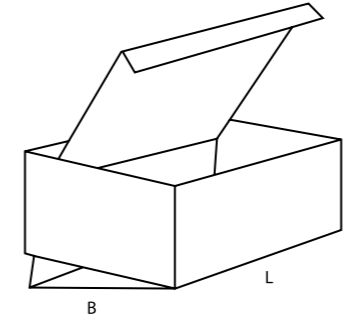

900 SERİSİ / Series 900

KUTU KODU
Box Code

3D ÇİZİM
3D Drawing

2D ÇİZİM
2D Drawing

0900

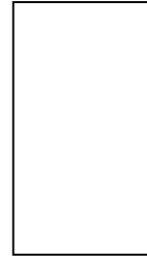
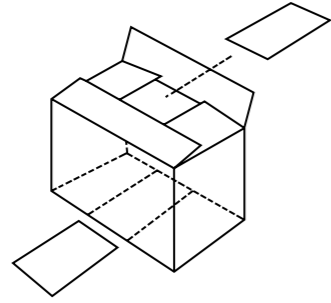

0901

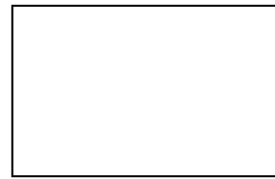
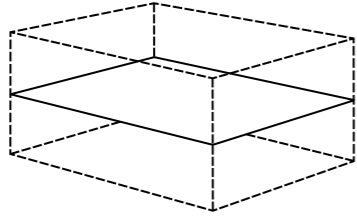

0904

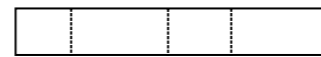
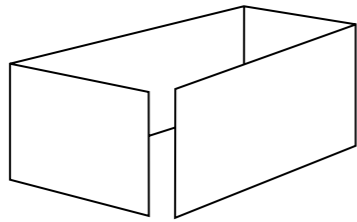

0908

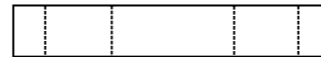
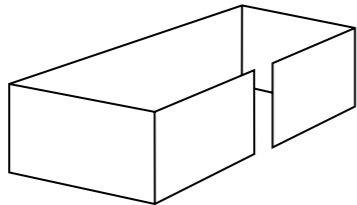

0910

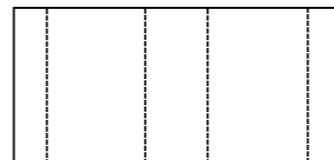
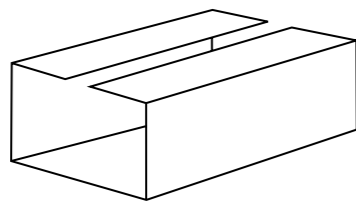

900 SERİSİ / Series 900

KUTU KODU
Box Code

3D ÇİZİM
3D Drawing

2D ÇİZİM
2D Drawing

0914

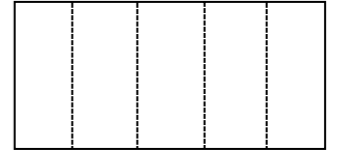
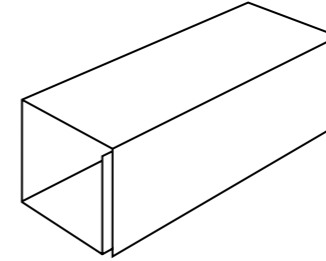

0920

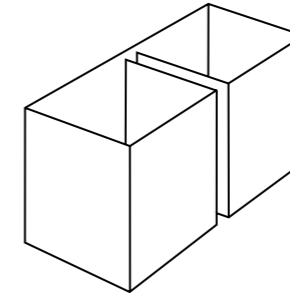

0921

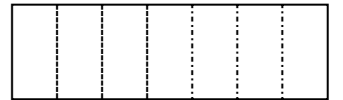
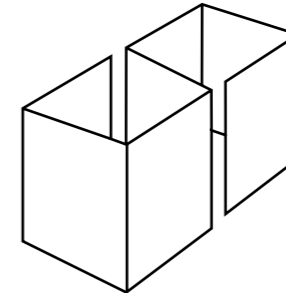

0931

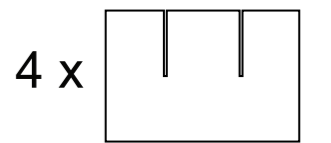
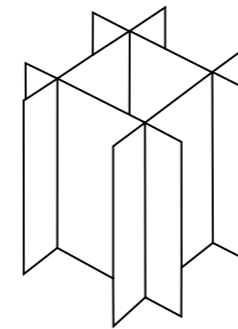

0941

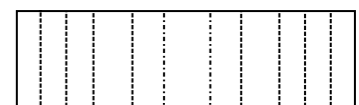
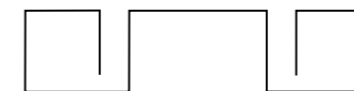

900 SERİSİ / Series 900

KUTU KODU
Box Code

3D ÇİZİM
3D Drawing

2D ÇİZİM
2D Drawing

0943

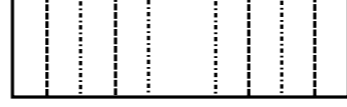

0945



0949

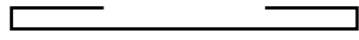

0970

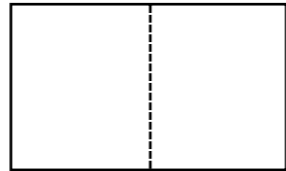
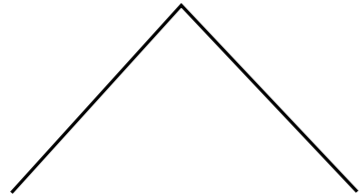

0971

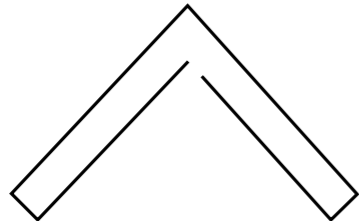

KUTU KODU
Box Code

3D ÇİZİM
3D Drawing

2D ÇİZİM
2D Drawing

0972

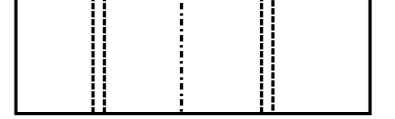
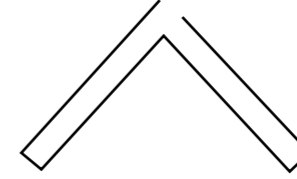

0973

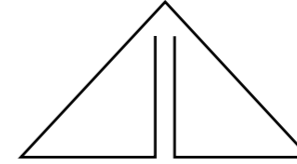

0974

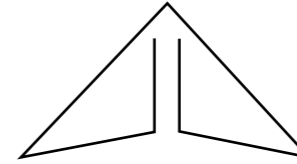

Notlar / Notes

.....

.....

.....

.....

.....

.....

.....

.....

.....

.....

.....

.....

.....

.....

.....

.....

.....

.....

.....

.....

.....

.....



 orimakmakine  orimak makine

Mahmudiye Mh. 19. Mob. Sk. No:2/E
İnegöl / BURSA / TÜRKİYE

+90 224 718 62 68
info@orimak.com
www.orimak.com

